

# JOBS DIMENSIONS

## CORSO 45

### STRAIGHT LINE

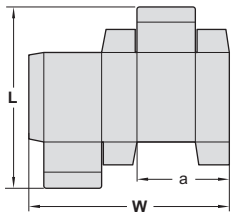

<b>L</b> max	800 mm / 31,50 in
<b>L</b> min	70 mm / 2,76 in
<b>W</b> max	450 mm / 17,72 in
<b>W</b> min	75 mm / 2,95 in
<b>a</b> min	35 mm / 1,38 in

**W** min = 45 mm / 1,77 in  
ON REQUEST

### DOUBLE WALL

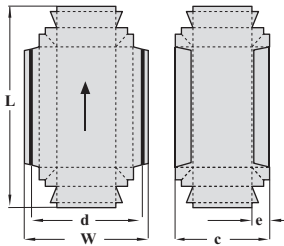

<b>L</b>	70 - 800 mm / 2,76 - 31,50 in
<b>W</b>	105 - 450 mm / 4,13 - 17,72 in
<b>c</b>	90 - 430 mm / 3,54 - 16,93 in
<b>d</b> max	440 mm / 17,32 in
<b>e</b> min	10 mm / 0,40 in

### LOCK BOTTOM

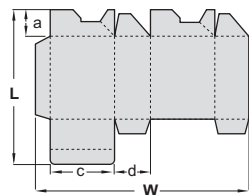

<b>L</b>	n.a. / n.a.
<b>W</b>	n.a. / n.a.
<b>c</b> min	n.a. / n.a.
<b>d</b> min	n.a. / n.a.
<b>a</b> max	n.a. / n.a.

## VERSO 60

### STRAIGHT LINE

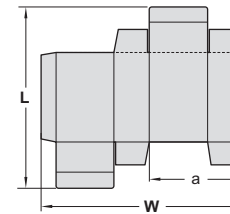

<b>L</b> max	600 mm / 23,62 in
<b>L</b> min	70 mm / 2,76 in
<b>W</b> max	600 mm / 23,62 in
<b>W</b> min	75 mm / 2,95 in
<b>a</b> min	35 mm / 1,58 in

**W** min = 45mm / 1,77 in  
with SMALL BOX ATTACHMENT

### DOUBLE WALL

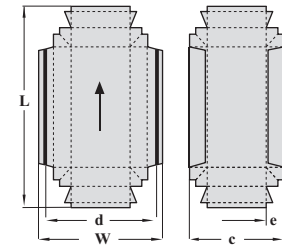

<b>L</b>	70 - 600 mm / 2,76 - 23,62 in
<b>W</b>	105 - 600 mm / 4,13 - 23,62 in
<b>c</b>	90 - 580 mm / 3,54 - 22,84 in
<b>d</b> max	590 mm / 22,23 in
<b>e</b> min	10 mm / 0,40 in

### LOCK BOTTOM

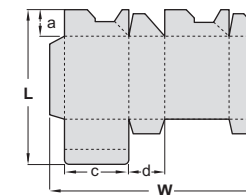

<b>L</b>	90 - 600 mm / 3,54 - 23,62 in
<b>W</b>	147 - 600 mm / 5,79 - 23,62 in
<b>c</b> min	40 mm / 1,57 in
<b>d</b> min	30 mm / 1,18 in
<b>a</b> min	20 mm / 0,80 in

**W** min = 110 mm / 4,33 in  
with SPECIAL ATTACHMENT

# TECHNICAL DATA

## MODULES OVERVIEW

1	Feeder
2	Prefolding section
3	Lockbottom module
4	Folding section
5	Pressing unit *
6	Transfer station
7	Squaring device *
8	Compression module
9	Delivery section

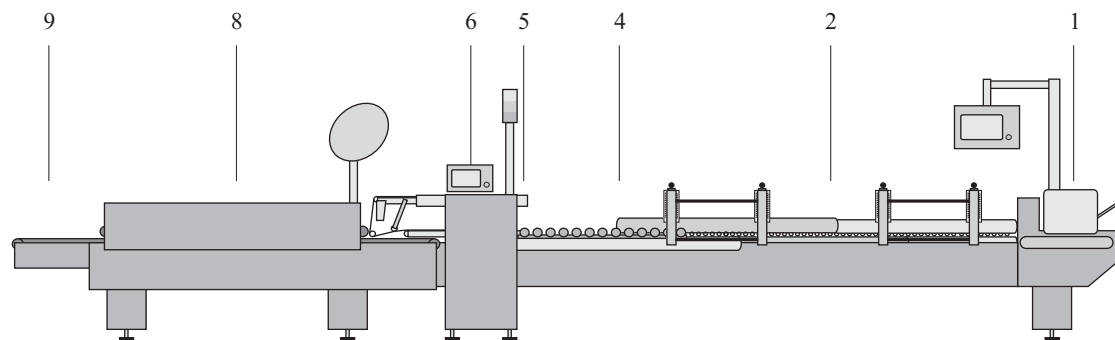

CORSO 45

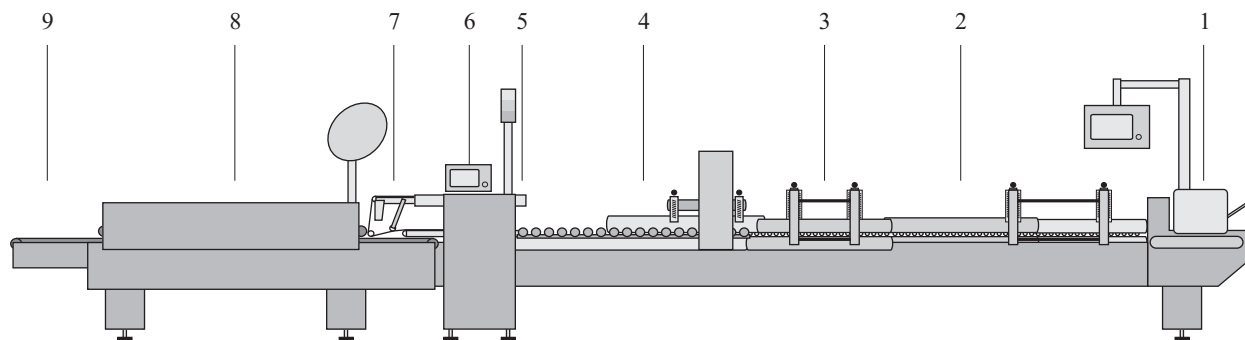

VERSO 60

CONVERTIBLE STOCK		CORSO 45	VERSO 60
Folding box board	GSM	200 - 600	200 - 600
Microflute	TYPE	N - F - E	N - F - E
Inching speed	m/min	10	10
Operating speed *	m/min	20-200	20-200
optional	m/min	20-300	20-300

INSTALLATION		CORSO 45	VERSO 60
Length	m	7,30	8,10
Width	m	0,85	1,00
Voltage	V	400 N-PE	400 N-PE
Motor power	kW	6,00	9,00
Compressed air	bar	6	6